



**finder**<sup>®</sup>  
SWITCH TO THE FUTURE

# Electronic step, call/reset and monostable relays



Call and reset switches  
for bathrooms



Bathrooms  
lighting control



Bedroom  
light control



Living room  
light control



Office lighting  
control



**13**  
SERIES



**13.81 - Electronic step relay - Rail mount - 1 Pole**

**13.91 - Electronic step relay and timing step relay  
Switch box mount - 1 Pole**

- Fixed time (10 minutes) timing function selectable (13.91)
- Use with 3 or 4 wire connection, with automatic recognition by the relay
- Control input can be continuously applied
- Longer mechanical and electrical life, and much quieter than electromechanical step relays
- "Zero crossing" load switching
- Can be mounted behind blanking plates, as widely used in residential wiring systems such as; BTicino: Axolute, Matix, Living and Magic, Gewiss: GW24, Vimar: Plana and Idea ... (13.91)
- 35 mm rail (EN 60715) mount (13.81)
- Cadmium free contact material

13.81/91  
Screw terminals



For outline drawing see page 16

**Contact specification**

Contact configuration		1 NO (SPST-NO)	1 NO (SPST-NO)
Rated current/Maximum peak current	A	16/30 (120 - 5 ms)	10/20 (80 - 5 ms)
Rated voltage/ Maximum switching voltage	V AC	230/—	230/—
Rated load AC1	VA	3700	2300
Rated load AC15 (230 V AC)	VA	750	450
Nominal lamp rating:			
230 V incandescent/halogen W		3000	1000
fluorescent tubes with electronic ballast W		1500	500
fluorescent tubes with electromechanical ballast W		1000	350
CFL W		600	300
230 V LED W		600	300
LV halogen or LED with electronic ballast W		600	300
LV halogen or LED with electromechanical ballast W		1500	500
Minimum switching load	mW (V/mA)	1000 (10/10)	1000 (10/10)
Standard contact material		AgSnO <sub>2</sub>	AgSnO <sub>2</sub>

**Supply specification**

Nominal voltage (U <sub>N</sub> )	V AC (50/60 Hz)	230	230
	V DC	—	—
Rated power	V A (50 Hz)/W	3/1.2	2/1
Operating range	AC (50 Hz)	(0.8...1.1)U <sub>N</sub>	(0.8...1.1)U <sub>N</sub>
	DC	—	—

**Technical data**

Electrical life at rated load in AC1	cycles	100 · 10 <sup>3</sup>	100 · 10 <sup>3</sup>
Maximum impulse duration		continuous	continuous
Dielectric strength between:			
open contacts V AC		1000	1000
supply - contacts V AC		—	—
Ambient temperature range	°C	-10...+60	-10...+50
Protection category		IP 20	IP 20

**Approvals** (according to type)



**13.81**



- 1 NO (SPST-NO)
- 35 mm rail (EN 60715) mount
- 17.5 mm wide

**13.91**



- 1 NO (SPST-NO)
- Step relay and timing step relay (10 minutes)
- For mounting within residential switch boxes

**13.01 - Electronic step/monostable relay  
Rail mount - 1 Pole**
**13.61 - Multifunction step/monostable relay  
with reset command - Rail mount 1 Pole**

- Selectable Step or Monostable operation (13.01)
- Multifunction (Step, Timing step, Monostable, Light ON) (13.61)
- Reset feature, for centralized off command (13.61)
- Set feature, for centralized on command (13.61.0.024)
- Control input can be continuously applied
- Longer mechanical and electrical life, and much quieter than electromechanical step relays
- 12...24 V AC/DC and 110...240 V AC supply versions (13.61)
- Suitable for SELV applications and available also for supply 12 and 24 V AC/DC (13.01)
- "Zero-crossing" load switching (13.61)
- 35 mm rail (EN 60715) mount
- Cadmium free contact material

13.01/61

Screw terminals



For outline drawing see page 16

**Contact specification**

Contact configuration		1 CO (SPDT)	1 CO (SPDT)	1 NO (SPST-NO)
Rated current/Maximum peak current	A	16/30 (120 A - 5 ms)	16/30 (120 A - 5 ms)	16/30 (120 A - 5 ms)
Rated voltage/ Maximum switching voltage	V AC	250/400	250/400	250/400
Rated load AC1	VA	4000	4000	4000
Rated load AC15 (230 V AC)	VA	750	750	750
Nominal lamp rating:				
230 V incandescent/halogen W		2000	2000	3000
fluorescent tubes with electronic ballast W		1000	1000	1500
fluorescent tubes with electromechanical ballast W		750	750	1000
CFL W		400	400	600
230 V LED W		400	400	600
LV halogen or LED with electronic ballast W		400	400	600
LV halogen or LED with electromechanical ballast W		800	800	1500
Minimum switching load	mW (V/mA)	1000 (10/10)	1000 (10/10)	1000 (10/10)
Standard contact material		AgSnO <sub>2</sub>	AgSnO <sub>2</sub>	AgSnO <sub>2</sub>

**K Supply specification**

Nominal voltage (U <sub>N</sub> )	V AC (50/60 Hz)	110...125	230...240	—	110...240
	V DC/AC (50/60 Hz)	12	24	12...24	—
Rated power AC/DC	V A (50/60 Hz)/W	2.5/2.5		1/0.5	3.2/1
Operating range	V AC (50 Hz)	90...130	184...253	—	90...264
	V DC/AC (50 Hz)	10.8...13.2	20.6...33.6	10.2...26.4	—

**Technical data**

Electrical life at rated load in AC1	cycles	100 · 10 <sup>3</sup>	100 · 10 <sup>3</sup>	100 · 10 <sup>3</sup>
Maximum impulse duration		continuous	continuous	continuous
Dielectric strength between:	open contacts V AC	1000	1000	1000
	supply - contacts V AC	4000	2000	2000
Ambient temperature range	°C	-10...+60	-10...+60	-10...+60
Protection category		IP 20	IP 20	IP 20

**Approvals (according to type)**

**13.01**

- 1 CO (SPDT)
- Step or monostable relay
- 35 mm rail (EN 60715) mount
- 35 mm wide

**13.61.0.024.0000**

- 1 CO (SPDT)
- Reset feature, for centralized off command
- Set feature, for centralized on command
- Multifunction:
  - step relay
  - timing step relay (30s...20min)
  - monostable relay
  - light on
- 35 mm rail (EN 60715) mount
- 17.5 mm wide

**13.61.8.230.0000**

- 1 NO (SPST-NO)
- Reset feature, for centralized off command
- Multifunction:
  - step relay
  - timing step relay (30s...20min)
  - monostable relay
  - light on
- 35 mm rail (EN 60715) mount
- 17.5 mm wide

### 13.11 - Call & Reset Relay - Rail mount - 1 Pole

### 13.12 - Call & Reset Relay - Rail mount - 2 Pole

### 13.31 - Electromechanical monostable relay Switch box mount - 1 Pole

- Call relay with reset command suitable for residential and commercial applications: public bathroom, hospital, hotel (type 13.11/13.12)
- Can be mounted behind blanking plates, as widely used in residential wiring systems such as; BTicino: Axolute, Matix, Living e Magic, Gewiss: GW24, Vimar: Plana e Idea ... (13.31)
- 35 mm rail (EN 60715) or flange mount (13.11 and 13.12)
- Cadmium free contact material (13.31)

13.11/12/31  
Screw terminals



\* During impulse only.  
For outline drawing see page 16

#### Contact specification

Contact configuration		1 CO (SPDT)	1 CO (SPDT) + 1 NO (SPST-NO)	1 NO (SPST-NO)
Rated current/Maximum peak current	A	12/30	8/15	12/20 (80 A - 5 ms)
Rated voltage/ Maximum switching voltage	V AC	250/400	250/400	250/400
Rated load AC1	VA	3000	2000	3000
Rated load AC15 (230 V AC)	VA	750	400	450
Nominal lamp rating:				
230 V incandescent/halogen	W	1200	800	800
fluorescent tubes with electronic ballast	W	500	300	400
fluorescent tubes with electromechanical ballast	W	400	250	300
CFL	W	300	150	200
230 V LED	W	300	150	200
LV halogen or LED with electronic ballast	W	300	150	200
LV halogen or LED with electromechanical ballast	W	500	300	400
Minimum switching load	mW (V/mA)	500 (5/5)	300 (5/5)	1000 (10/10)
Standard contact material				
		AgCdO	AgCdO	AgSnO <sub>2</sub>
<b>Supply specification</b>				
Nominal voltage (U <sub>N</sub> )	V AC (50/60 Hz)	230...240	12 - 24	12 - 230
	V DC	—	12 - 24	24
Rated power AC/DC	V A (50 Hz)/W	1.7/0.7*	3/2.5*	1/0.4
Operating range	AC (50 Hz)	(0.8...1.1)U <sub>N</sub>	(0.8...1.1)U <sub>N</sub>	(0.8...1.1)U <sub>N</sub>
	DC	—	(0.8...1.1)U <sub>N</sub>	(0.8...1.1)U <sub>N</sub>
<b>Technical data</b>				
Electrical life at rated load in AC1	cycles	100 · 10 <sup>3</sup>	100 · 10 <sup>3</sup>	70 · 10 <sup>3</sup>
Maximum impulse duration		10 s (100 ms minimum)	10 s (100 ms minimum)	continuous
Dielectric strength between:				
open contacts	V AC	1000	1000	1000
supply - contacts	V AC	2000	2000	2000
Ambient temperature range	°C	-10...+60	-10...+60	-10...+60
Protection category		IP 20	IP 20	IP 20

**Approvals** (according to type)



### 13.11



- 1 CO (SPDT)
- Call relay with reset command
- 35 mm rail (EN 60715) mount
- 17.5 mm wide

### 13.12



- 1 CO (SPDT) + 1 NO (SPST-NO)
- Call relay with reset command
- 35 mm rail (EN 60715) mount
- 17.5 mm wide

### 13.31



- 1 NO (SPST-NO)
- Interposing monostable relay
- For mounting within residential switch boxes

**Electronic multifunction relay with Bluetooth****13.22 - Electronic multifunction relay  
2 contacts**

- Wall round box (ie: Ø 60 mm) mounting
- 20 available functions (step relays, timer, staircase timer) for lighting and fan motor

**13.72 - Electronic multifunction relay  
2 contacts**

- Wall mounting, compatible with most common italian residential switch boxes: AVE, BTicino, Gewiss, Simon-Urmet, Vimar
- 21 available functions: step relays, timing (1s - 24h), electric blinds or electric curtains

**13.S2 - Electronic multifunction relay  
2 contacts**

- Wall round box (ie: Ø 60 mm) mounting
- For shutters or electric curtains
- 2 contacts NO 6 A - 230 V AC independent and programmable channels
- 2 inputs for wired push-buttons (one input per channel)
- Transmission range: approximately 10 m in free space and without obstacles

13.22/S2/72

Screw terminals



For outline drawing see page 16

**Contact specification**

Contact configuration		2 NO (DPST-NO)	2 NO (DPST-NO)	2 NO (DPST-NO)
Rated current/Maximum peak current	A	6/40	6/40	6/40
Rated voltage/ Maximum switching voltage	V AC	230/—	230/—	230/—
Rated load AC1	VA	1380	1380	1380
Rated load AC15 (230 V AC)	VA	300	300	300
Single phase motor rating (230 V AC)	W	200	200	200
Nominal lamp rating 230V:				
incandescent/halogen W		200	200	—
fluorescent tubes with electronic ballast W		200	200	—
fluorescent tubes with electromechanical ballast W		200	200	—
CFL W		200	200	—
LED 230 V W		200	200	—
LV halogen or LED with electronic ballast W		200	200	—
LV halogen or LED with electromechanical ballast W		200	200	—

**Supply specification**

Nominal voltage (U <sub>N</sub> )	V AC (50/60 Hz)	230	230	230
	V DC	—	—	—
Rated power AC/DC	V A (50 Hz)/W	2/0.5	2/0.5	2/0.5
Operating range	AC (50 Hz)	(0.8...1.1)U <sub>N</sub>	(0.8...1.1)U <sub>N</sub>	(0.8...1.1)U <sub>N</sub>
	DC	—	—	—

**Technical data**

Electrical life at rated load in AC1	cycles	60 · 10 <sup>3</sup>	60 · 10 <sup>3</sup>	60 · 10 <sup>3</sup>
Maximum impulse duration		continuous	continuous	continuous
Dielectric strength between: open contacts	V AC	1000	1000	1000
Ambient temperature range	°C	-10...+50	-10...+50	-10...+50
Protection category		IP 20	IP 20	IP 20

**Approvals (according to type)****NEW 13.22**

YESLY



- It can carry out a variety of ON/OFF functions associated with lighting and fan motor
- Transmission protocol Bluetooth 4.2 Low Energy
- Safe connection with 128-bit encryption
- App programming with iOS or Android Smartphone: Finder TOOLBOX
- Can be managed through standard pushbuttons, BEYON wireless buttons and Type 013.B9

**NEW 13.72**

YESLY



- It can carry out a variety of ON/OFF functions associated with lighting, electric shutters or power curtains
- Transmission protocol Bluetooth 4.2 Low Energy
- Safe connection with 128-bit encryption
- App programming with iOS or Android Smartphone: Finder TOOLBOX
- Can be managed through standard pushbuttons, BEYON wireless buttons and Type 013B9

**NEW 13.S2**

YESLY



- Suitable for electric shutters or power curtains
- Transmission protocol Bluetooth 4.2 Low Energy
- Safe connection with 128-bit encryption
- App programming with iOS or Android Smartphone: Finder TOOLBOX
- Can be managed through standard pushbuttons, BEYON wireless buttons and Type 013.B9

## Ordering information

Example: Multifunction relay with Bluetooth YESLY, 2 contacts 6 A NO (SPST-NO), 230 V AC supply.

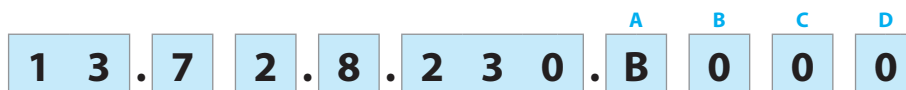

**Series**

**Type**

- 0 = Step/Monostable, 35 mm rail (EN 60715) mount, 35 mm wide
- 1 = Call & Reset relay, 35 mm rail (EN 60715) mount, 17.5 mm wide
- 2 = YESLY - multifunction relay, wall box mounting
- 3 = Monostable relay, switch box mounting
- 6 = Multifunction relay, 35 mm rail (EN 60715) mount, 17.5 mm wide
- 7 = YESLY - Multifunction relay compatible with the most popular wall switch systems: AVE, BTicino, Gewiss, Simon-Urmet, Vimar
- 8 = Modular step relay, 35 mm rail (EN 60715) mount, 17.5 mm wide
- 9 = Step relay and timing step relay, switch box mounting
- S = YESLY - Shutter/curtains actuator, wall box mounting

**No. of poles**

- 1 = 1 pole
- 2 = 2 poles 6 A NO (SPST-NO) (type 13.72 and 13.22/S2)
- 2 = 1 pole CO (SPDT) + 1 NO (SPST-NO)

**Supply version**

- 0 = AC (50/60 Hz)/DC
- 8 = AC (50/60 Hz)
- 9 = DC

**Supply voltage**

- 012 = 12 V AC/DC (13.01 and 13.12 only)
- 012 = 12 V AC (13.31 only)
- 024 = 24 V AC/DC (13.01 and 13.12 only)
- 024 = 24 V DC (13.31 only)
- 024 = 12...24 V AC/DC (13.61 only)
- 125 = (110...125)V AC (13.01 only)
- 230 = (230...240)V AC (13.01 and 13.11)
- 230 = 110...240 V AC (13.61 only)
- 230 = 230 V AC (13.31, 13.22, 13.52, 13.72, 13.81 and 13.91)

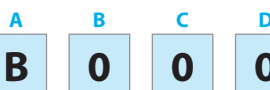

0 = Type 13.72 white  
2 = Type 13.72 anthracite gray

**A: Transmission protocol**  
(only for Type 13.22/S2/72)  
B = Bluetooth 4.2 Low Energy

**A: Contacts material**  
0 = Standard  
4 = Standard AgSnO<sub>2</sub> (only for 13.31)

**B: Contact circuit**  
0 = Standard  
3 = Standard NO (only for 13.31)

**Codes / Supply voltage**

- 13.01.0.012.0000 12 V AC/DC
- 13.01.0.024.0000 24 V AC/DC
- 13.01.8.125.0000 110...125 V AC
- 13.01.8.230.0000 230...240 V AC
- 13.11.8.230.0000 230...240 V AC
- 13.12.0.012.0000 12 V AC/DC
- 13.12.0.024.0000 24 V AC/DC
- 13.22.8.230.B000 230 V AC Yesly
- 13.52.8.230.B000 230 V AC Yesly
- 13.31.8.012.4300 12 V AC
- 13.31.9.024.4300 24 V DC
- 13.31.8.230.4300 230 V AC
- 13.61.8.230.0000 110...240 V AC
- 13.61.0.024.0000 12...24 V AC/DC
- 13.72.8.230.B000 Yesly BLE white
- 13.72.8.230.B002 Yesly BLE anthracite gray
- 13.81.8.230.0000 230 V AC
- 13.91.8.230.0000 230 V AC

## Technical data

Insulation		13.01.8	13.01.0	13.11 - 13.12	13.31 - 13.61	13.81 - 13.91			
Dielectric strength	between control circuit and supply	V AC 4000	—	—	—	—			
	between control circuit and contacts	V AC 4000	4000	—	—	—			
	between R-S-A2 and contacts	V AC —	—	2000	—	—			
	between supply and contacts	V AC 4000	4000	—	2000	—			
	between open contacts	V AC 1000	1000	1000	1000	1000			
<b>Other data</b>		<b>13.01</b>		<b>13.11 - 13.12</b>	<b>13.31</b>	<b>13.61</b>	<b>13.81</b>	<b>13.91</b>	<b>13.22</b> <b>13.52</b> <b>13.72</b>
Power lost to the environment	without contact current	W 2.2	—	0.4	1	1.2	0.7	0.5	
	with rated current	W 3.5	1.5	1.6	1.8	2	1.8	1.5	
Max cable length for push-button connection	m	100	100	—	200	200	100	100	
Max. no. of illuminated push-button	(≤1mA)	—	—	—	10*	15	12	5	
<b>Terminals</b>		<b>13.01</b>		<b>13.11 - 13.12 - 13.31 - 13.61 - 13.72 - 13.81 - 13.91</b>			<b>13.22 - 13.52</b>		
Max. wire size		solid cable	stranded cable	solid cable	stranded cable	solid cable	stranded cable		
	mm <sup>2</sup>	1 x 6 / 2 x 4	1 x 6 / 2 x 2.5	1 x 6 / 2 x 4	1 x 4 / 2 x 2.5	2 x 1.5	2 x 1		
	AWG	1 x 10 / 2 x 12	1 x 10 / 2 x 14	1 x 10 / 2 x 12	1 x 12 / 2 x 14	2 x 16	2 x 16		
Screw torque	Nm	0.8		0.8					

\* For 8.230 version.

Functions for types 13.01, 13.11, 13.12, 13.81, 13.91

Type	Functions	
13.01		<b>Monostable</b> On closure of a switch between terminals (B2-B3) the output contact will close, and remain so, until the switch opens.
		<b>Step relay (bistable)</b> After every impulse (B1-B2), the output contact changes state - alternately switching from open to closed and vice versa.
13.11 13.12		<b>Call and Reset relay</b> On momentary closure of the Set switch (S), the output contact closes. Only a momentary closure of the Reset switch (R) will open the output contact.
13.81		<b>(RI) Step relay</b> After every impulse, the output contact changes state - alternately switching from open to closed and vice versa.
13.91		<b>(RI) Step relay</b> After every impulse, the output contact changes state - alternately switching from open to closed and vice versa.
		<b>(IT) Timing step relay</b> On initial impulse the output contact closes and timing starts for the pre-set duration (fixed 10 min); On expiry of the time delay, the output contact opens. During the timing period it is possible to immediately open the contact with a further impulse.

Operating mode setup for type 13.91

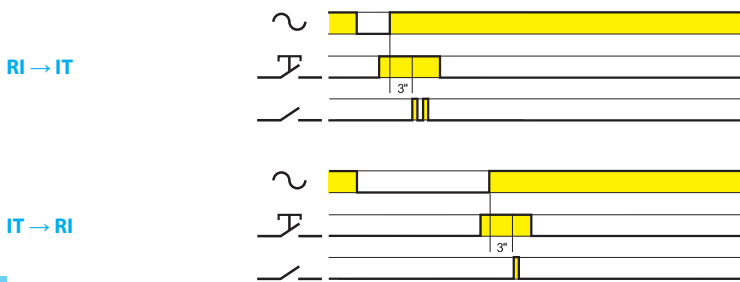

- Remove the supply voltage
- Press the control button
- Apply the supply to the relay, keeping the button closed. After 3 second, the light will flash twice to indicate the selection of the "IT" function, or flash once for "RI" function.

Functions for type 13.61

Type	Functions
13.61.8.230	<p><b>(RM) Monostable</b> On closure of a switch between terminal 3 and Line (or Neutral, in case of 3-wire connection) the output contact will close, and remain so, until the switch opens.</p>
	<p><b>(IT) Timing step relay</b> On initial impulse the output contact closes and timing starts for the pre-set duration T; On expiry of the time delay, the output contact opens. During the timing period it is possible to immediately open the contact with a further impulse. Switch-off delay time: 30s...20min</p>
	<p><b>(RI) Step relay</b> After every impulse, the output contact changes state - alternately switching from open to closed and vice versa.</p>
	<p><b>Light ON</b> With this function set - the output contact stays permanently closed.</p>
13.61.0.024	<p><b>(RM) Monostable</b> On closure of a switch between terminal 3 and Line (or Neutral, in case of 3-wire connection) the output contact will close, and remain so, until the switch opens.</p>
	<p><b>(IT) Timing step relay</b> On initial impulse the output contact closes and timing starts for the pre-set duration T; On expiry of the time delay, the output contact opens. During the timing period it is possible to immediately open the contact with a further impulse. Switch-off delay time: 30s...20min</p>
	<p><b>(RI) Step relay</b> After every impulse, the output contact changes state - alternately switching from open to closed and vice versa.</p>
	<p><b>Light ON</b> With this function set - the output contact stays permanently closed.</p>

## Functions for type 13.22, 13.S2, 13.72

### Relay settings

Multifunction electronic relay can be configured with Finder TOOLBOX App, available on iOS or Android systems. This product is ready-to-use with the factory setting: (RI) Step relay on both channels.

Type	Functions
13.22 13.72	<p><b>(RM) Monostable relay.</b> On closure of a switch the output will close, and remain so, until the switch opens.</p>
	<p><b>(RI) Step relay.</b> After every impulse, the output contact changes state - alternately switching from open to closed and vice versa.</p>
	<p><b>(LE) Asymmetric flasher (starting pulse on) with control signal.</b> Power is permanently applied to the timer. Closing Signal Switch (S) causes the output contacts to transfer immediately and cycle between ON (T1) and OFF (T2), until opened.</p>
	<p><b>(DE) Interval with control signal on.</b> Power is permanently applied to the timer. On momentary or maintained closure of Signal Switch (S), the output contacts transfer, and remain so for the duration of the preset delay, after which they reset.</p>
	<p><b>(BE) Staircase timer.</b> On initial impulse the output contact closes and timing starts for the pre-set duration; subsequent impulses during the timing period will extend the timing period by the full pre-set value. On expiry of the time delay, the output contact opens.</p>
	<p><b>(ME) Staircase timer + Staircase maintenance.</b> In addition to the Staircase timer function (BE), an impulse of <math>\geq 5</math> seconds will close the output contact for 60 minutes, after which time the contact will open. Ideal for maintenance or cleaning activities. The 60 minute timing can be interrupted by a further impulse of <math>\geq 5</math> seconds, and the output contact then opens.</p>
	<p><b>(BP) Staircase timer with switch off early warning.</b> On initial impulse the output contact closes and the timing starts for the pre-set duration. After the timing period, the output contact blinks off once; 10" later the contact blinks off twice, and after a further 10" the contact opens. During the pre-set and 20 second warning time, it is possible, by a further impulse, to extend the time by the full pre-set value.</p>
	<p><b>(MP) Staircase timer with switch off early warning + staircase maintenance.</b> In addition to the Staircase timer function (BP), an impulse of <math>\geq 5</math> seconds will close the output contact for 60 minutes, after which time the output contact blinks off once; 10" later the contact blinks off twice, and after a further 10" the contact will open. Ideal for maintenance or cleaning activities. The 60 minute timing can be interrupted by a further impulse of <math>\geq 5</math> seconds, and the output contact then opens.</p>

## Functions for type 13.22, 13.S2, 13.72

Type	Functions
13.22 13.72	<p><b>(IT) Timing step relay.</b> On initial impulse the output contact closes and timing starts for the pre-set duration; On expiry of the time delay, the output contact opens. During the timing period it is possible to immediately open the contact with a further impulse.</p>
	<p><b>(IP) Timing step relay with switch off early warning.</b> On initial impulse the output contact closes and timing starts for the pre-set duration; After the timing period, the output contact blinks off once; 10" later the contact blinks off twice, and after a further 10" the contact opens. During the pre-set and 20 second warning time, it is possible to immediately open the output contact by a further impulse.</p>
	<p><b>(FZ) Timing monostable.</b> On closure of a switch the output will close, and remain so, until the switch opens. If the switch remain close, the output will open when the time T1 will expired.</p>
	<p><b>(VB) Bathroom light + fan.</b> The contact Ch1 closes when the P1 command is pressed. When time T1 is up, Ch1 will be opened. The contact Ch2 closes when the P1 command is pressed. When time T1+T2 is up, Ch2 will be opened. The timing T1 can be reset by acting again on the P1 command.</p>
	<p><b>(CP) Ringbell + light.</b> The contact Ch1 closes when the P1 command is pressed. When time T1 is up, Ch1 will be opened. The contact Ch2 closes on activation and executes the blinking function with the time T2 until the time T1 is up. Each time the P1 command is pressed again, the timer T1 resumes with the set time.</p>
13.S2 13.72	<p><b>(TP) Shutter.</b> When P1 is pressed (&lt;1s), linked with "up", the contact Ch1 waits, then it closes for time T1. By pressing the button P1 again, contact Ch1 opens immediately. If the P1 command is maintained for more than 1s, the Ch1 contact will immediately open when the command is released. The same operation for the Ch2 contact combined with the P2 command, used to control the "down" function.</p>

## Sequences

**P1 (SET):** proceed with the sequence

**P2 (RESET):** bring the sequence to the first status

Type	Number of steps	Sequences			
		1	2	3	4
13.22 13.72	02				
	03				
	04				
	05				
	06				
	07				
	08				

Wiring diagrams (13.01, 13.11, 13.12 and 13.31)

**Type 13.01**

Step wiring diagram

Red LED indication:  
Continuous = relay ON

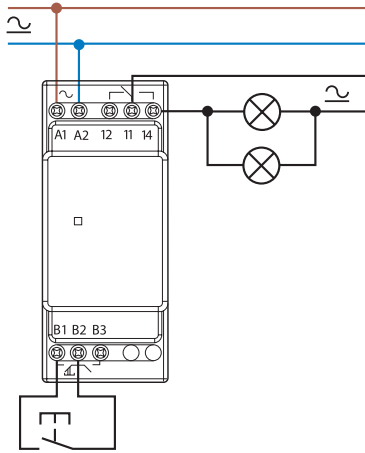

**Type 13.01**

Monostable wiring diagram

Red LED indication:  
Continuous = relay ON

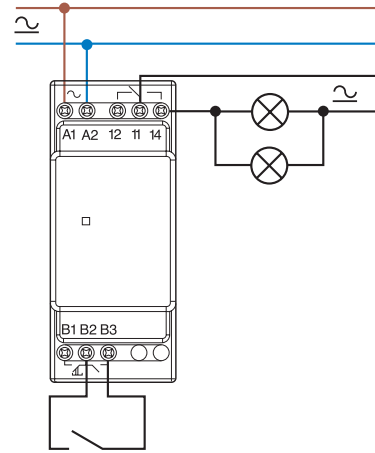

**Type 13.11**

Call & reset relay

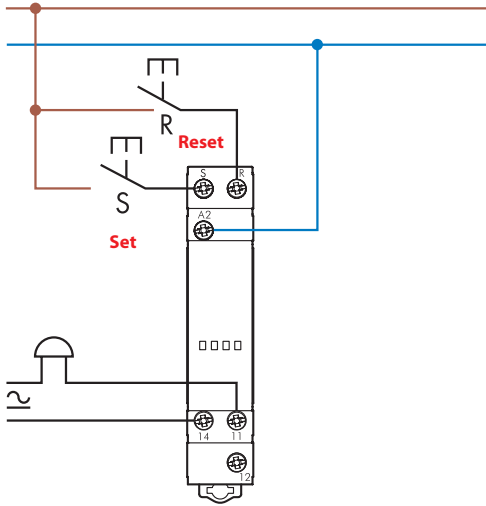

**Type 13.12**

Call & reset relay

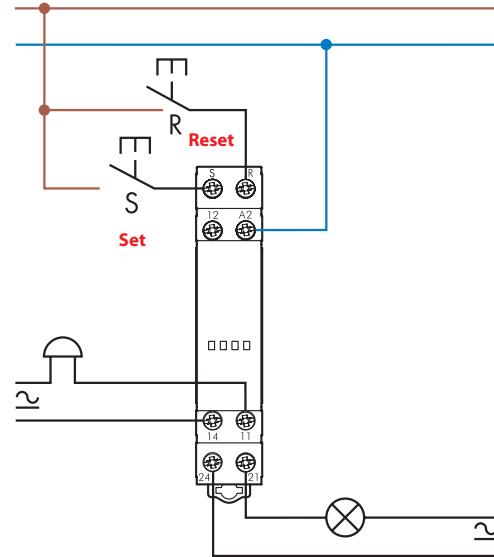

**Type 13.31**

Connection

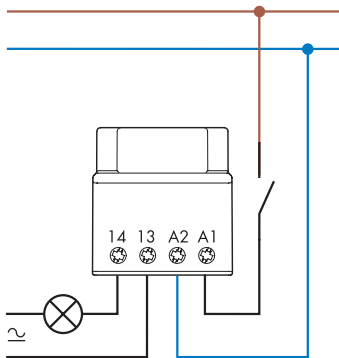

K

**Wiring diagrams (13.61)**

**Type 13.61.8.230**

3 wire connection  
Red LED indication:  
Continuous = relay ON  
Blinking = relay OFF

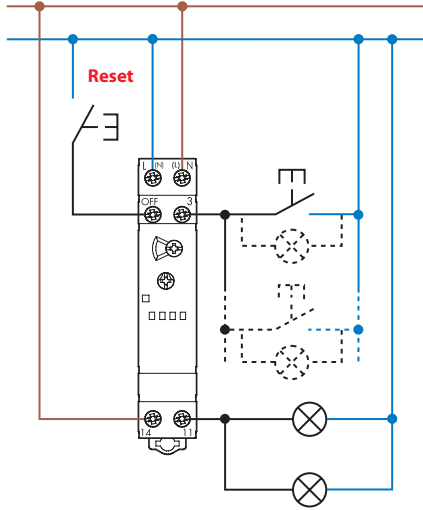

Max 10 ( $\leq 1$  mA)  
illuminated push buttons

**Type 13.61.8.230**

4 wire connection  
Red LED indication:  
Continuous = relay ON  
Blinking = relay OFF

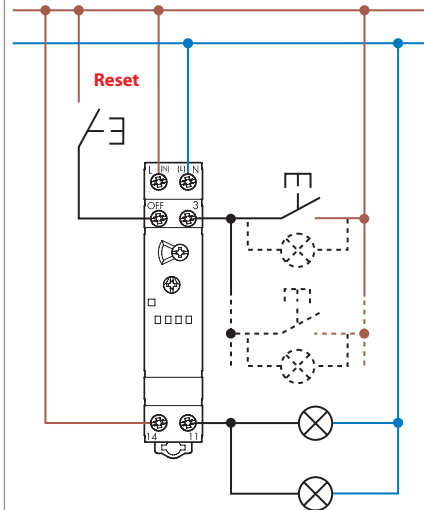

Max 10 ( $\leq 1$  mA)  
illuminated push buttons

**Type 13.61.0.024**

4 wire connection  
Red LED indication:  
Continuous = relay ON  
Blinking = relay OFF

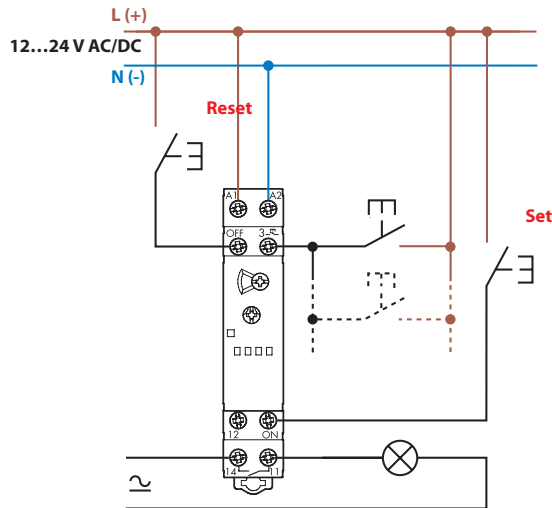

**Type 13.61.8.230 - Examples of multiple 4 wire connection with centralized reset pushbutton**

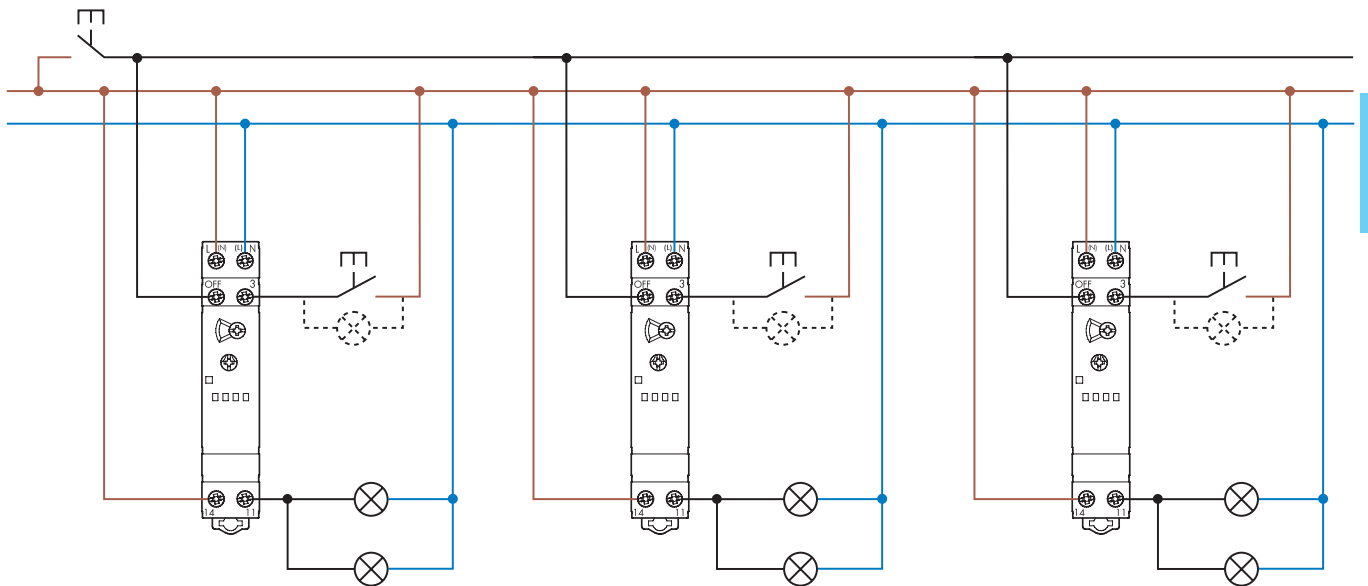

**K**

Wiring diagrams (13.81, 13.91, 13.22 and 13.S2)

**Type 13.81**

3 wire connection  
Red LED indication: a  
Continuous = relay ON  
Blinking = relay OFF

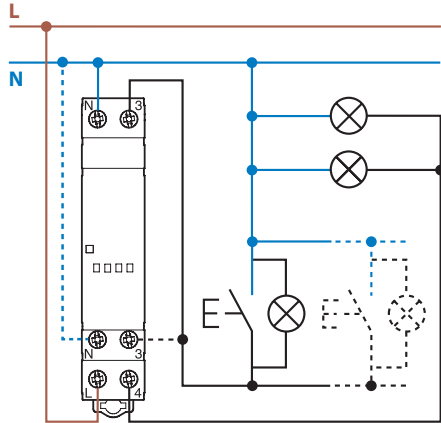

Max 15 ( $\leq 1$  mA)  
illuminated push buttons

**Type 13.81**

4 wire connection  
Red LED indication: a  
Continuous = relay ON  
Blinking = relay OFF

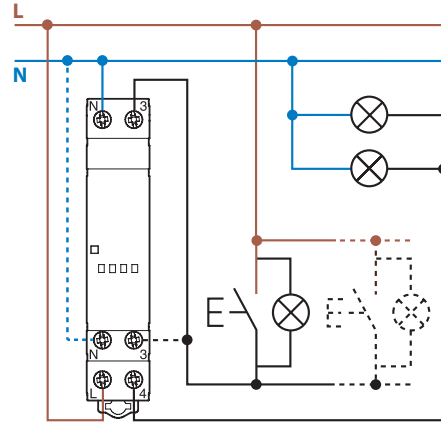

Max 15 ( $\leq 1$  mA)  
illuminated push buttons

**Type 13.91**

3 wire connection

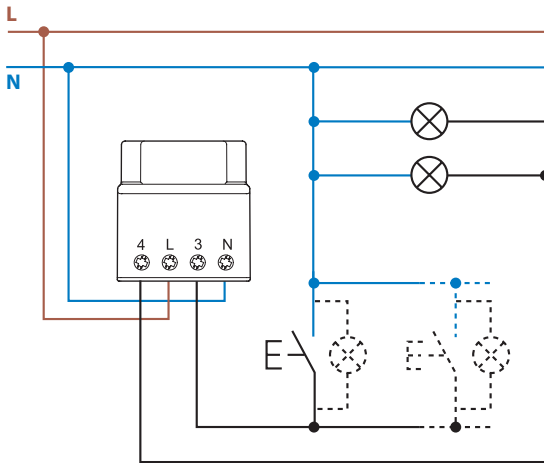

Max 12 ( $\leq 1$  mA)  
illuminated push buttons

**Type 13.91**

4 wire connection

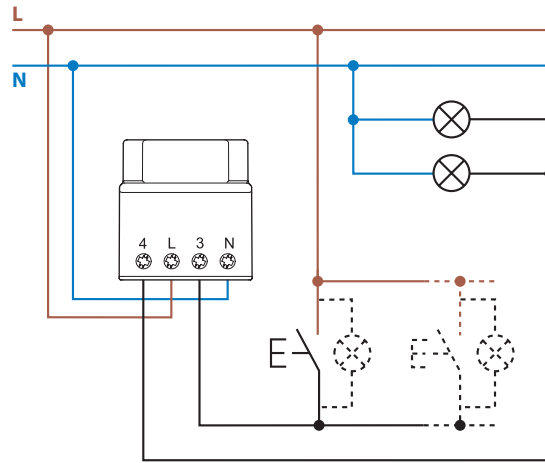

Max 12 ( $\leq 1$  mA)  
illuminated push buttons

**Type 13.22**

4 wire connection

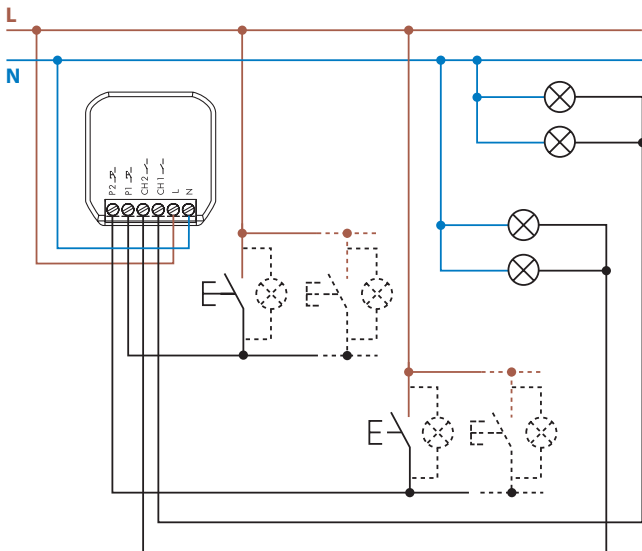

Max 5 ( $\leq 1$  mA)  
illuminated push buttons

**Type 13.S2**

4 wire connection

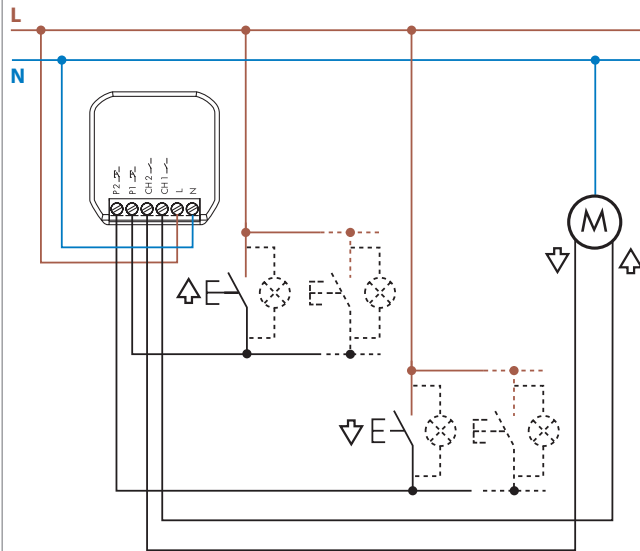

Max 5 ( $\leq 1$  mA)  
illuminated push buttons

K

**Wiring diagrams (13.72)**

**Type 13.72**  
4 wire connection

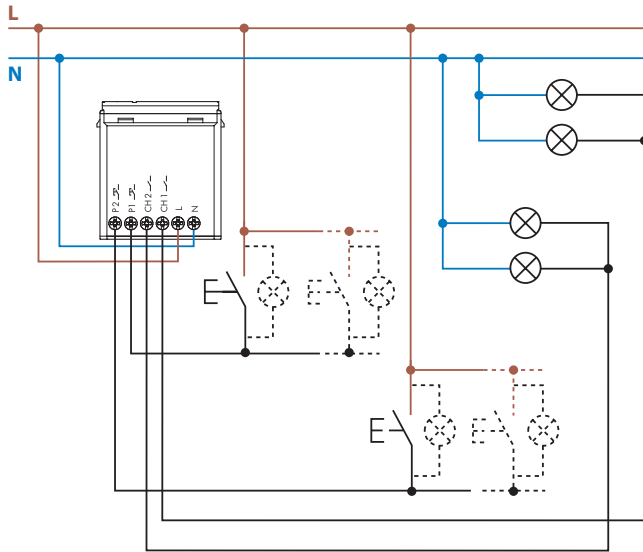

Max 5 ( $\leq 1$  mA)  
illuminated push buttons

**Examples of applications**

**Type 13.72**

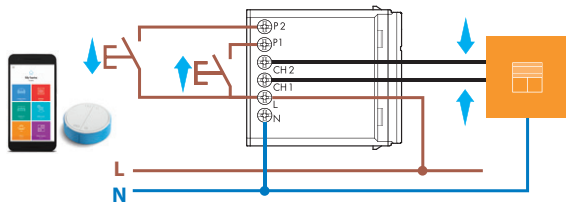

Ch1-P1: up  
Ch2-P2: down

**Function TP - Blinds**

**Type 13.S2**

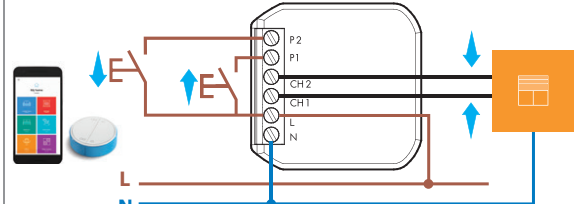

Ch1-P1: up  
Ch2-P2: down

**Type 13.72**

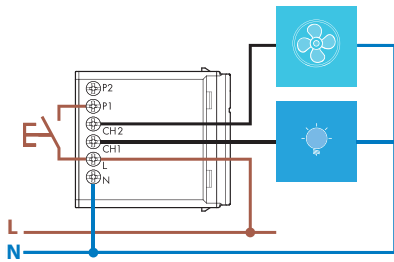

**Function VB - Bathroom light + fan**

**Type 13.22**

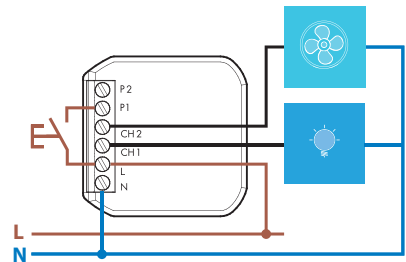

**Type 13.72**

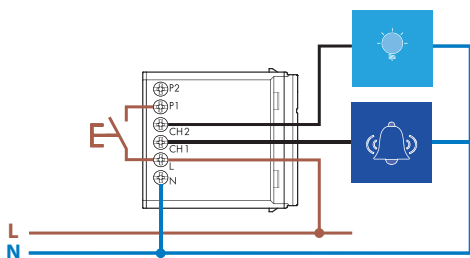

**Function CP - Ringbell + Lights**

**Type 13.22**

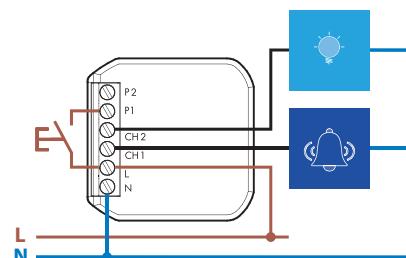

## Outline drawings

Type 13.01  
Screw terminal

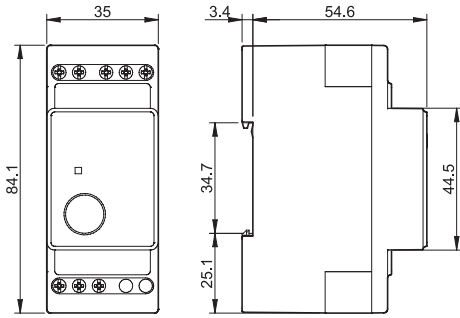

Type 13.11  
Screw terminal

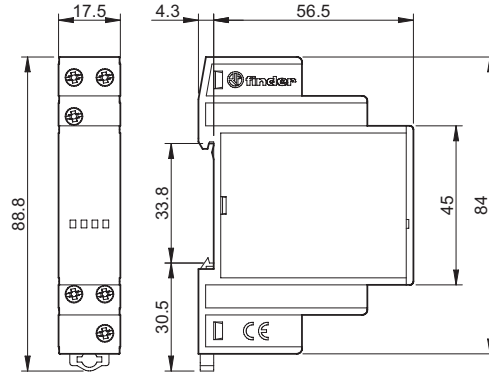

Type 13.12  
Screw terminal

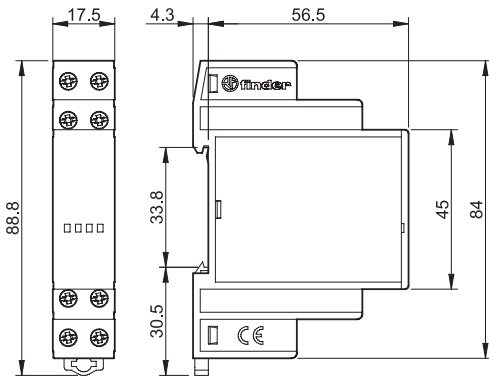

Types 13.31/13.91  
Screw terminal

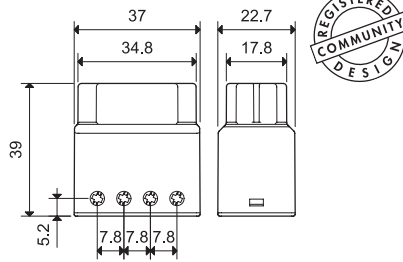

Type 13.61  
Screw terminal

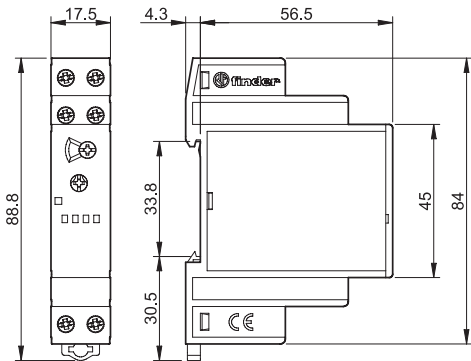

Type 13.81  
Screw terminal

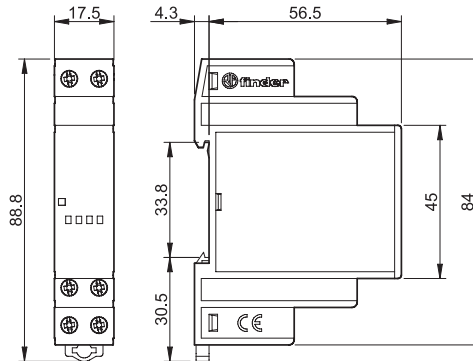

K

## Outline drawings

Type 13.72  
Screw terminal

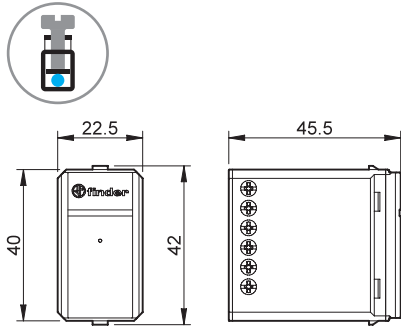

Type 13.22 / 13.52  
Screw terminal

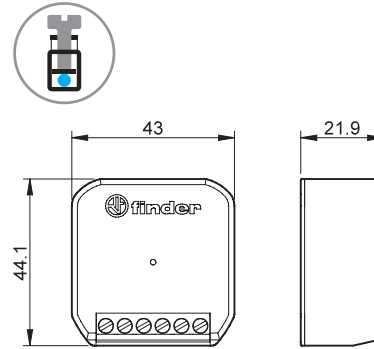

## Accessories



**011.01**

**Adaptor for panel mounting, for type 13.01, 35 mm wide**

011.01



**020.01**

**Adaptor for panel mounting, for type 13.11, 13.12, 13.61 and 13.81, 17.5 mm wide**

020.01

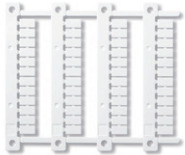

**060.48**

**Sheet of marker tags (CEMBRE Thermal transfer printers) for relays types 13.11, 13.12, 13.61 and 13.81 (48 tags), 6 x 12 mm**

060.48

